

LEKTRO

Model AP8800SDA-EZ AIRCRAFT TOWING VEHICLE FOR AIRCRAFT UP TO 90,000 LBS/40,824 KG

1190 S.E. Flightline Drive, Warrenton, Oregon 97146-9692
1-800-535-8767 • 503-861-2288 • Fax 503-861-2283
E-mail: sales@lektro.com
http://www.lektro.com

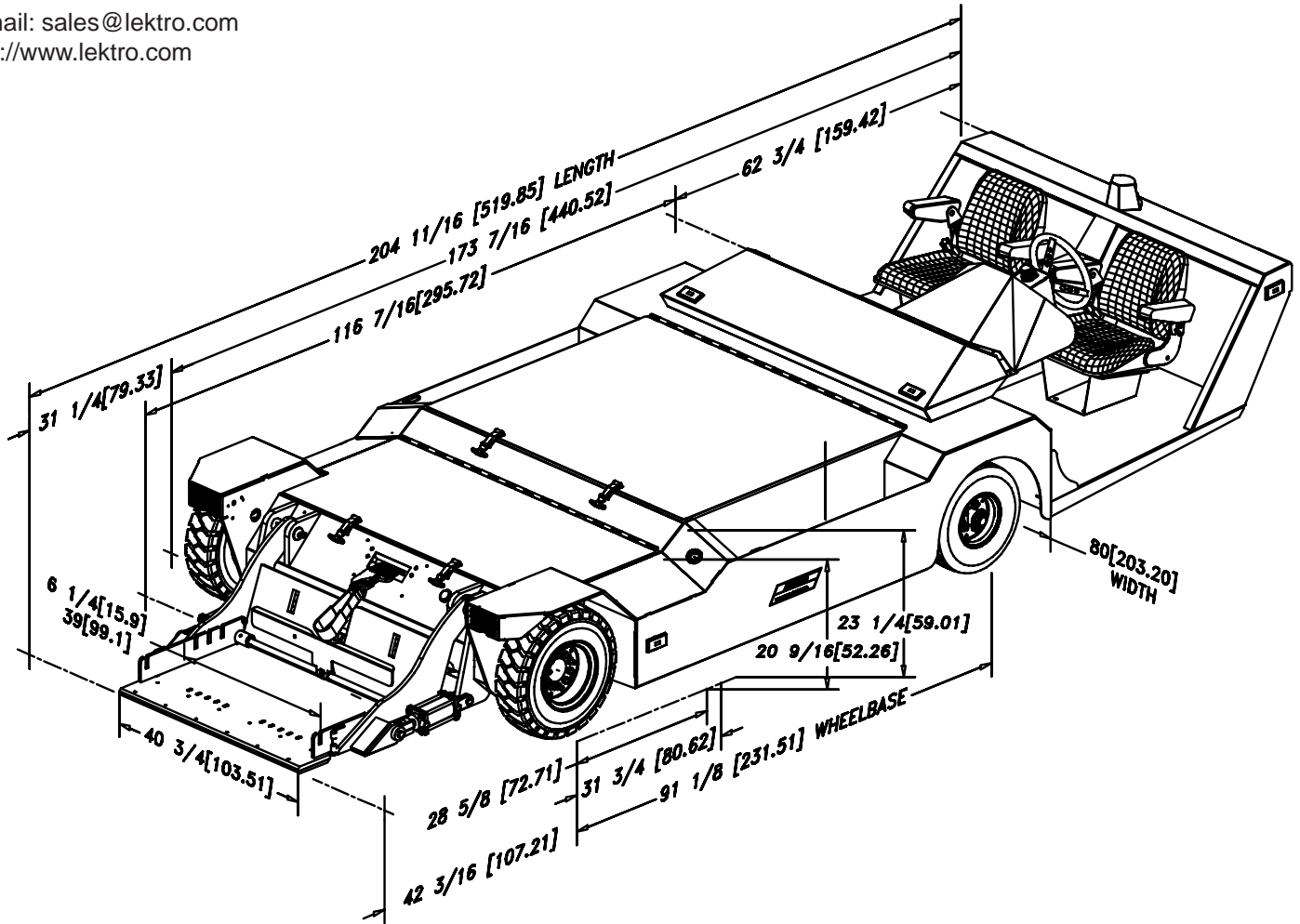

AP8800SDA-EZ FEATURES:

Vehicle Drive: Heavy-duty 9 inch frame, 72-volt D.C. Traction Motor coupled direct to a heavy-duty Dana 44 Differential. Limited Slip Differential, Optional.

Motor Speed Control: State of the art General Electric EV-200 LXT Electronic Speed Control with on-board trouble shooting diagnostics. Speed controlled by Foot Throttle.

Batteries: Six 12-volt, 390 ampere hour Batteries (20 hr. rate), wired in series.

G. P.U.: Built-in 12/24/28 volt, 1175 cold cranking ampere output capability with independent batteries and charging system, Optional.

Motive Battery Charger: Fully automatic 40 ampere, 220-volt, 50/60hz, Single Phase Charger, standard.

Nose Gear Lift Cradle: Lektro's patented Universal Nose Gear Lift Cradle is activated by an Electric/Hydraulic pump assembly with dual cylinders, and is capable of handling dual and single wheel aircraft. A hold down provision for light-nosed aircraft, Optional.

Winch: Heavy-duty Hydraulic Winch with automatic safety cut-off. Winch Strap and universal Strut Straps included.

Steering: Electric/Hydraulic Power Steering controlled through automotive-type tilt wheel requiring minimal effort with very responsive steering action. Automatic timer shuts down steering motor when tug is not in use, increasing battery shift life.

Service Brakes: Foot operated dual independent hydraulic disc-type Service Brakes utilizing the final wheel drive gearing to achieve maximum braking with minimal brake pedal effort.

Parking Brake: Hand activated, industry standard, "yellow diamond" push/pull electric/hydraulic Parking Brake, coupled to brake discs on final drive.

Drive Tires: Single 6.50 x 10 10-ply Pneumatic Traction Drive Tires. Chains optional for slippery conditions. Poly-foam filled tires available.

Steering Tires: 5.70 x 8 8-Ply Pneumatic Highway Steer Tires mounted to a fully suspended steer axle.

Lighting: Dual Forward Headlights, standard. Dual Aft Headlights, Optional. Four amber reflectors positioned around tug to illuminate sides and top. Amber Strobe Light mounted center rear and Flashing Running Lights, Optional.

Seating: Operator and passenger seating, forward facing, constructed of industrial grade, weather resistant materials including armrests and seat belt. Dual facing passenger/operator's helm, Optional. Operator's cab with heater, defroster, and windshield wipers, Optional.

Construction: Welded steel plate and polymers preserved by primer and automotive high-gloss red enamel paint. A special protective Polyurethane coating applied to decks, fenders, side and battery compartments to prevent rust, scratches and corrosion as well as custom colors are optional.

SPECIFICATIONS:

Length	205 in / 520 cm
Width	80 in / 203 cm
Height (At lowest steering tilt setting)	37 in / 94 cm
Turning Radius	180 in / 457 cm
Wheel Base	91 in / 231 cm
Vehicle Speed, Empty	9 m.p.h. / 14.5 kph
Vehicle Speed, Loaded (To Max. Vehicle Capacity)	4 m.p.h. / 6.4 kph
**Lift Cradle Capacity	9,000 lbs / 4082 kg
Nose Gear Cradle Lifting Height	9 in / 23 cm
Ground Clearance	5 in / 12.7 cm
Chassis Weight w/o Batteries & Charger	5330 lbs / 2418 kg
Chassis Weight w/ Motive Batteries & Charger	7000 lbs / 3175 kg
Chassis Weight w/ Motive & GPU Batteries & Charger ..	7350 lbs / 3334 kg

**Lift Capacity is calculated with 20 in / 51 cm diameter aircraft tire in lift cradle. Aircraft tire center line at 23 in / 58 cm from drive tire center line.

ADDITIONAL OPTIONS:

Pintle Towing Hook, Specialized Aircraft Towing Adapters and Custom Highlift Adapters are available (consult factory). Illustration may show some optional equipment.

*LEKTRO reserves the right to make changes and improvements in products and specifications without notice or obligation.

PATENT Nos. 5,261,778/5,302,075. Other Patents Pending.

11/08