

LEKTRO

1190 S.E. Flightline Drive, Warrenton, Oregon 97146-9692
 1-800-535-8767 • 503-861-2288 • Fax 503-861-2283
 E-mail: sales@lektro.com
 http://www.lektro.com

Model AP8700C-EZ AIRCRAFT TOWING VEHICLE FOR AIRCRAFT UP TO 55,000 LBS/24,948 KG

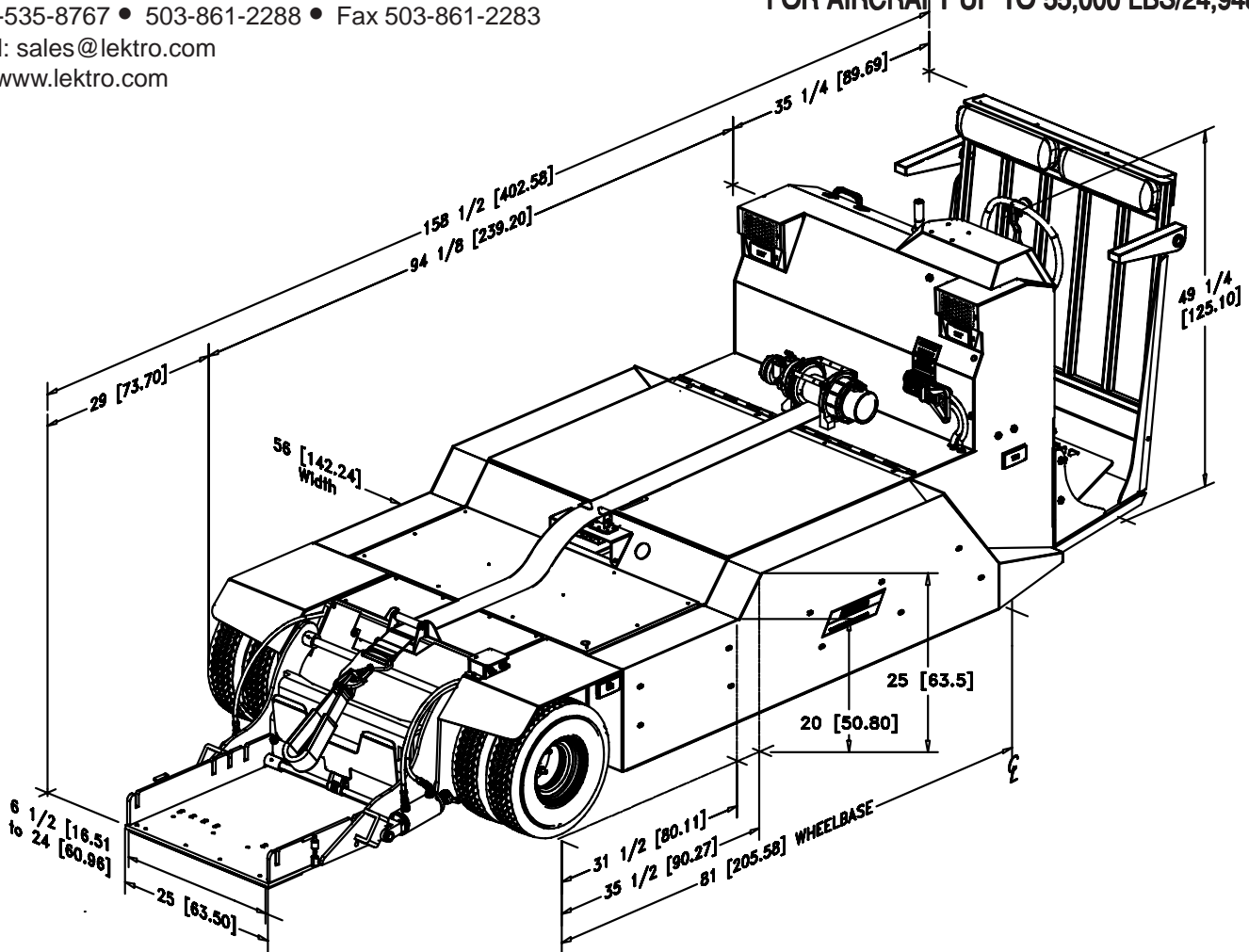

AP8700C-EZ FEATURES:

Vehicle Drive: Heavy-duty 9 inch frame, 48-volt D.C. Traction Motor coupled to a heavy-duty Dana 44 Differential. Limited Slip Differential, Optional.

Motor Speed Control: State of the art General Electric EV-100 LXT Electronic Speed Control with on-board trouble shooting diagnostics. Speed controlled by combination Hand Throttle/Directional Lever.

Batteries: Eight 6-volt, 350 ampere hour Batteries (20 hr. rate), wired in series. Additional Battery options available, (consult factory).

G.P.U.: Variety of GPU options available, (consult factory).

Battery Charger: Fully automatic 50 ampere D.C., 220-volt A.C., 60 hz, Single Phase Charger, standard. 50 hz, Optional.

Nose Gear Lift Cradle: Lektro's patented Universal Nose Gear Lift Cradle is activated by an Electric/Hydraulic pump assembly with dual cylinders, and is capable of handling dual and single wheel aircraft. A hold down provision for light-nosed aircraft as well as Wheel Faring package, Optional.

Winch: Heavy-duty Hydraulic Winch with automatic safety cut-off. Winch Strap and universal Strut Strap included.

Steering: Automotive-type wheel coupled to an automotive gear box resulting in very responsive steering action.

Service Brakes: Foot operated dual independent hydraulic disc-type Service Brakes at each drive wheel.

Parking Brake: Foot operated mechanical / hydraulic activated Automatic Parking Brake.

Front Drive Tires: Dual 5.00 x 8 8-ply Pneumatic Highway Drive Tires. Traction Tires and Chains optional for slippery conditions. Poly-foam filled tires available.

Rear Steer Tires: Dual 5.00 x 8 8-ply Pneumatic Highway Steer Tires. Poly-foam filled tires available. Steer Axle Suspension, Optional.

Lighting: Dual Forward Headlights, standard. Dual Aft Headlights, Optional. Five amber Reflectors positioned around tug to illuminate sides, top and rear. Flashing Running Lights, Optional.

Extension Ladder: Four-step Ladder attached to operator's back rest is optional.

Operator's Compartment: Two person configuration, stand-up operation with restraint.

Construction: Welded steel plate and polymers preserved by primer and automotive high-gloss red enamel paint. A special protective Polyurethane coating applied to decks, fenders, side and battery compartments to prevent rust, scratches and corrosion as well as custom colors are optional.

SPECIFICATIONS:

Length	158.5 in / 403 cm
Width	56 in / 142 cm
Height	49.25 in / 125 cm
Turning Radius	139 in / 353 cm
Wheel Base	81 in / 206 cm
Vehicle Speed, Empty	7 m.p.h. / 11.2 kph
Vehicle Speed, Loaded (To Max. Vehicle Capacity)	3 m.p.h. / 4.8 kph
**Lift Cradle Capacity	5500 lbs / 2495 kg
Nose Gear Cradle Lifting Height	9 in / 23 cm
Ground Clearance	5 in / 12.7 cm
Chassis Weight w/o Batteries & Charger	2970 lbs / 1347 kg
Chassis Weight w/ Motive Batteries & Charger	4250 lbs / 1928 kg
Chassis Weight w/ Motive & GPU Batteries & Charger ..	4600 lbs / 2087 kg

**Lift Capacity is calculated with 18 in / 46 cm diameter aircraft tire in lift cradle. Aircraft tire center line at 20.5 in / 52 cm from drive tire center line.

ADDITIONAL OPTIONS:

Pintle Towing Hook, Specialized Aircraft Towing Adapters and Custom Highlift Adapters are available (consult factory). Illustration may show some optional equipment.

*LEKTRO reserves the right to make changes and improvements in products and specifications without notice or obligation.

PATENT Nos. 5,151,003/5,302,075. Other Patents Pending.